

# Hellas

Antti Evävaara



**Martela**



#### HELLAS

##### Materiaalit:

Runko puuta. Jalusta mahonkia, kirsikkapuuta, pyökkiä tai petsattua pyökkiä. Ympäriverhoiltu. Irralliset istuintynyt.

##### Paino:

HLS1	24,0 kg
HLS2	45,0 kg
HLS3	65,0 kg
HLS4	25,0 kg
HLS80	20,0 kg
HLS143	25,0 kg
HLSP/100x50	15,0 kg
HLSP/50x50	10,0 kg
HLSP/40x40	8,0 kg

##### Kangasmenekki:

HLS1	3,2 m
HLS2	5,5 m
HLS3	7,0 m
HLS4	2,4 m
HLS80	1,7 m
HLS143	2,4 m

Pakkaukset kierrätettäviä, tuotteiden materiaalit uusiokäyttökelpoisia tai poltettavia.

#### HELLAS

##### Material:

Stomme i trä. Fötter i mahogny, körsbärsträd, lackad bok eller betsad bok. Helt tygklädd. Lösa sittdynor.

##### Vikt:

HLS1	24,0 kg
HLS2	45,0 kg
HLS3	65,0 kg
HLS4	25,0 kg
HLS80	20,0 kg
HLS143	25,0 kg
HLSP/100x50	15,0 kg
HLSP/50x50	10,0 kg
HLSP/40x40	8,0 kg

##### Tygätgång:

HLS1	3,2 m
HLS2	5,5 m
HLS3	7,0 m
HLS4	2,4 m
HLS80	1,7 m
HLS143	2,4 m

Förpackningar är återvinningsbara och produktens material kan användas på nytt eller brännas.

#### HELLAS

##### Materials:

Wooden frame. Legs available in mahogany, cherry, lacquered beech or stained beech. Fully upholstered and detachable seat cushion.

##### Weight:

HLS1	24.0 kg
HLS2	45.0 kg
HLS3	65.0 kg
HLS4	25.0 kg
HLS80	20.0 kg
HLS143	25.0 kg
HLSP/100x50	15.0 kg
HLSP/50x50	10.0 kg
HLSP/40x40	8.0 kg

##### Fabric consumption:

HLS1	3,2 m
HLS2	5,5 m
HLS3	7,0 m
HLS4	2,4 m
HLS80	1,7 m
HLS143	2,4 m

The packaging is recyclable and the product materials are reusable or combustible.

#### HELLAS

##### Materialien:

Gestell aus Holz

##### Gewicht:

HLS1	24,0 kg
HLS2	45,0 kg
HLS3	65,0 kg
HLS4	25,0 kg
HLS80	20,0 kg
HLS143	25,0 kg
HLSP/100x50	15,0 kg
HLSP/50x50	10,0 kg
HLSP/40x40	8,0 kg

##### Stoffbedarf:

HLS1	3,2 m
HLS2	5,5 m
HLS3	7,0 m
HLS4	2,4 m
HLS80	1,7 m
HLS143	2,4 m

Verpackungen recyclebar, die verwendeten Materialien können wiederverwertet oder verbrannt werden.

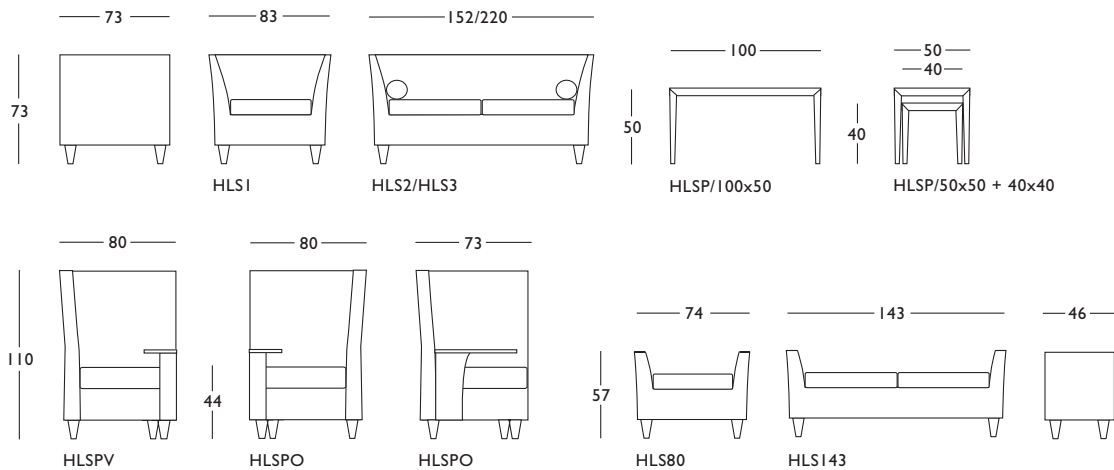

www.martela.com